



**BILFINGER**

**Babcock Noell GmbH**

## **Technological Infrastructure and Industry: a success story SC Magnets**

Michael Gehring

AMICI Partner and Industry Days for Scientific Technology Infrastructure, Padova 18/19. April 2017

# Introduction

- Introducing Babcock Noell GmbH
- Success story fusion magnets
- Success story light sources
- Success story accelerators
- Factors for the success



# Babcock Noell: Member of Bilfinger SE

Bilfinger SE

Business Segment  
Industrial

Business Segment  
Power

Business Segment  
Building & Facility

Business Segment  
Construction

Piping  
Systems

Power  
Systems

Babcock  
Noell GmbH



Nuclear Services



Nuclear Technologies

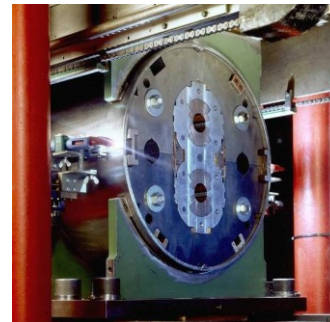

Magnet Technologies



Environmental  
Technologies

# We are Magnet Technology

- Physicists, Engineers and Technicians work hand-in-hand
- More than 30 years magnet technology experience
- Cooperation with research institutions and industry

**WE  
MAKE  
RESEARCH  
WORK!**

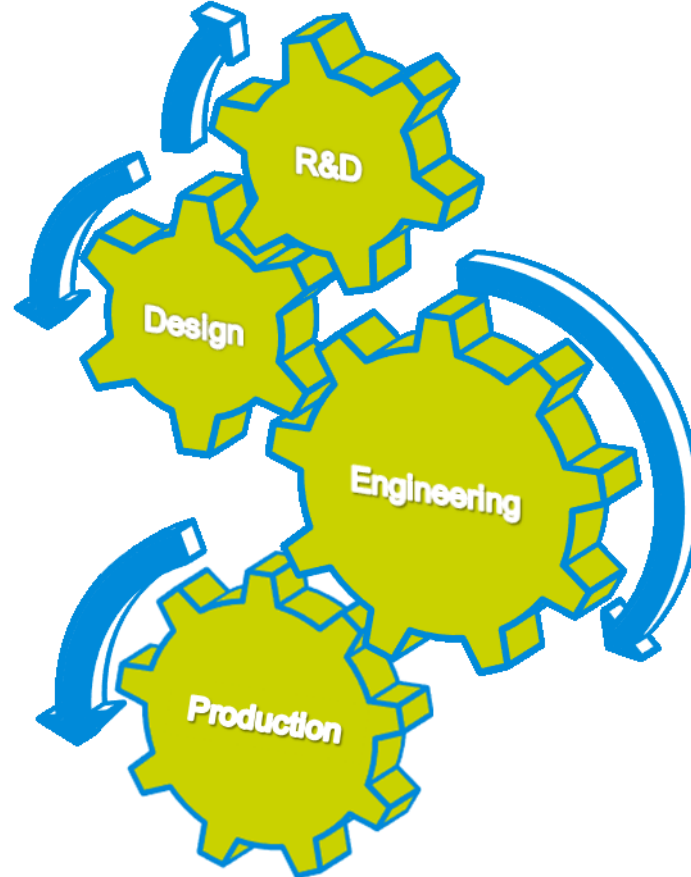

# Site and Location



Office



1. Workshop: 2.100m<sup>2</sup>

2. Workshop: 1.000m<sup>2</sup>

3. Workshop: 1.100m<sup>2</sup>



# Success story fusion magnets

# Cooperation between research organisations and industry

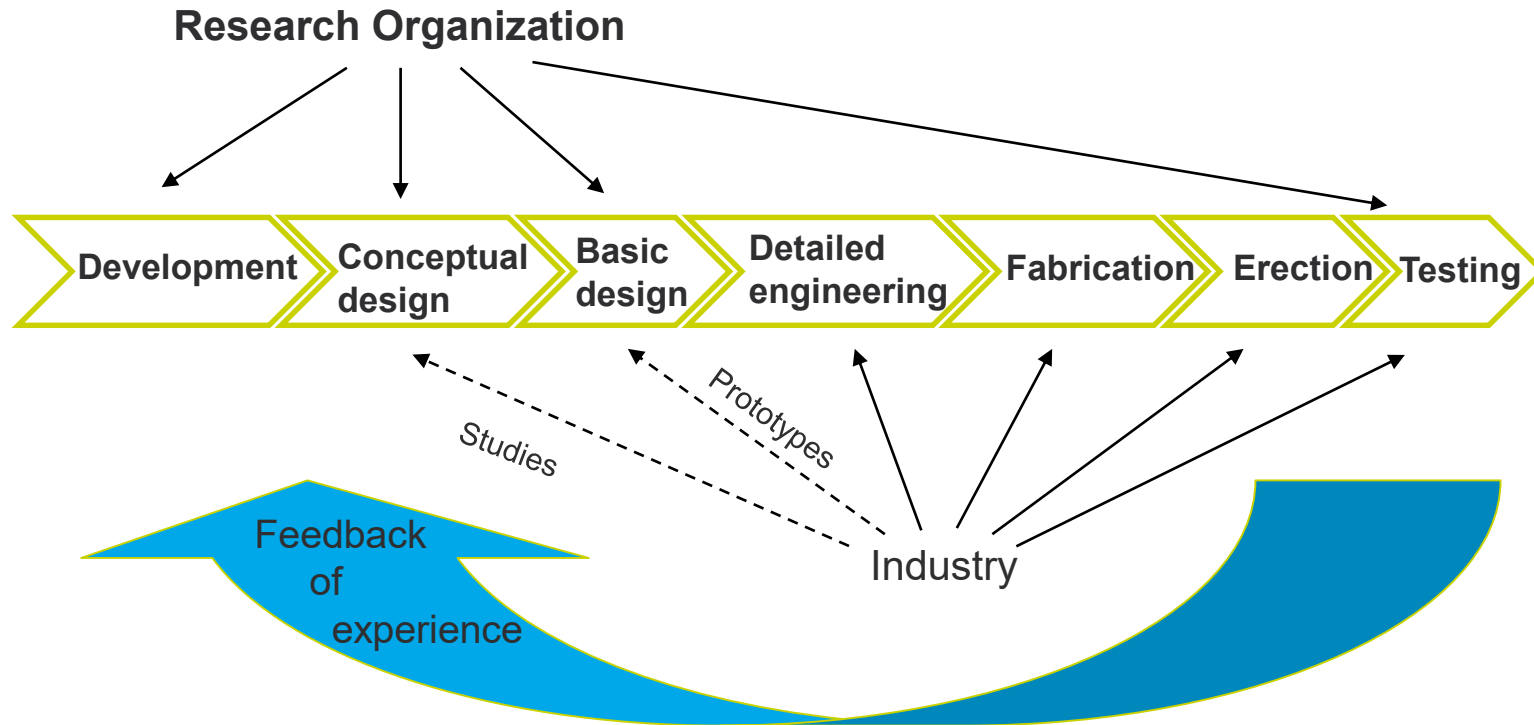

# Experience with “Non-planar coils for Wendelstein 7-X” Development Phase

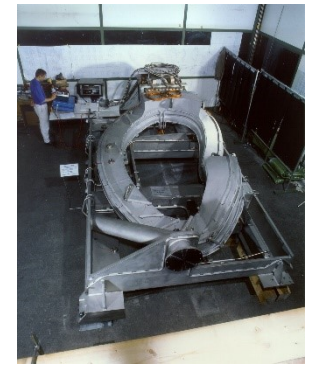
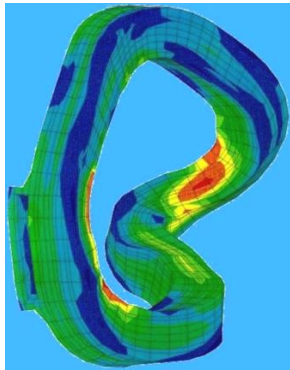
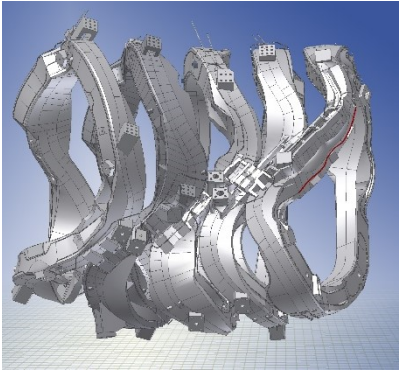

- EM and basic design by IPP
- Manufacturing design by industry
- Conductor development transferred to industry in early phase
- DEMO coil manufactured with industrial responsibility
- Industrial network in the contractual phase for main components established (conductor, case, winding pack, etc.)
- Test of DEMO Coil at KIT

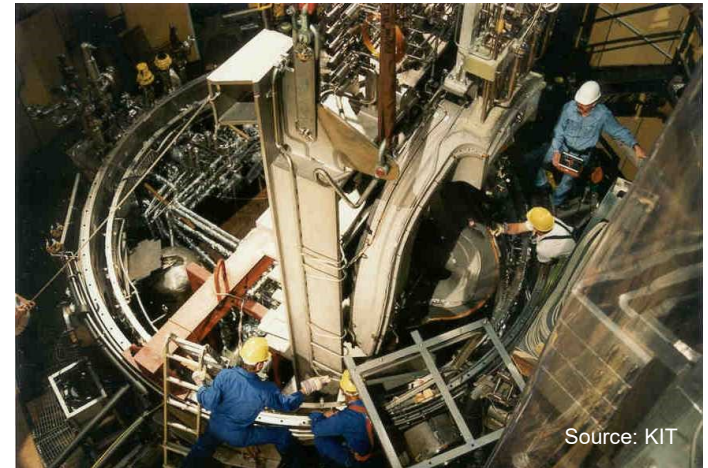



# Experience with “Non-planar coils for Wendelstein 7-X” Production Phase

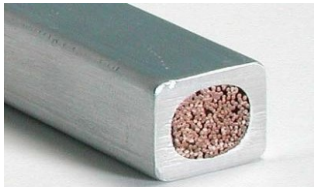

- EM and basic design by IPP, Manufacturing design by industry
- Responsibility for conductor, tools, manufacturing completely with industry
- Established industrial network in the contractual phase for main components
- Optimisations of production method by industry (casing, assembly, welding...)
- Tests of series coils at CEA before assembly and test by IPP in Greifswald



# Collaboration: Example W7-X Industrial Network for a complex project

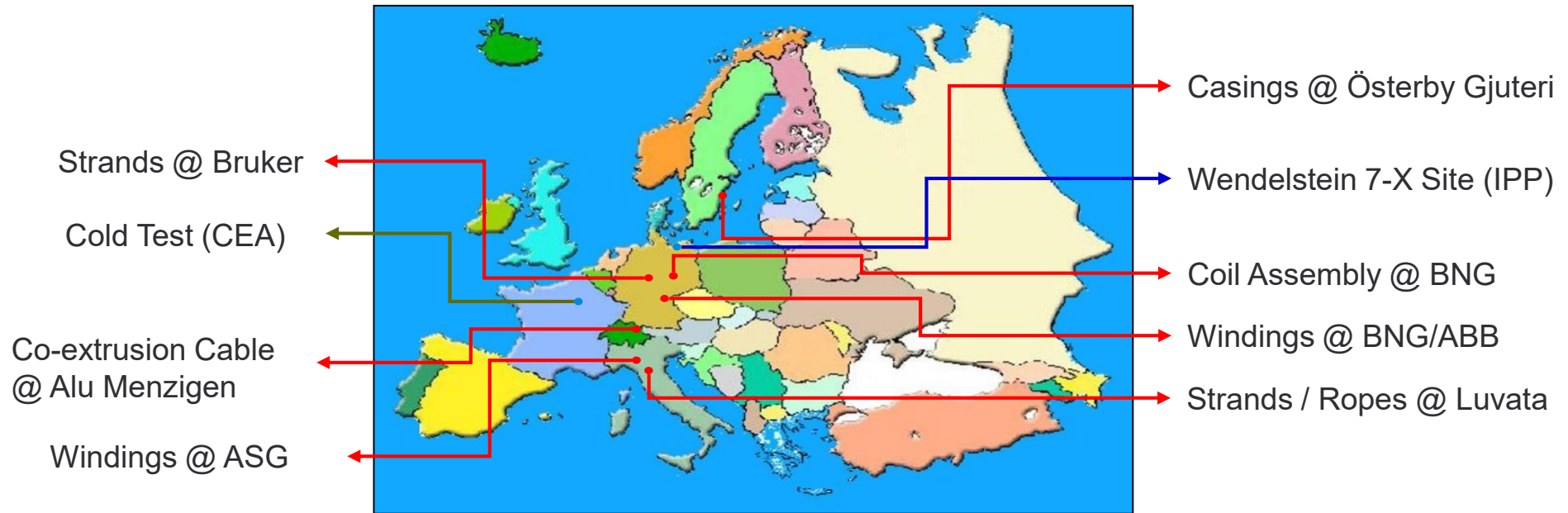

- International industrial consortium for fabrication
- Many companies from all over Europe involved
- Network established by industry

# Experience with “Non-planar coils for Wendelstein 7-X”

## Success story



Final acceptance of nonplanar coils

### Wendelstein 7-X fusion device produces its first hydrogen plasma

Federal Chancellor switches plasma on / Start of scientific experimentation

February 03, 2016

The Wendelstein 7-X fusion device at Max Planck Institute for Plasma Physics (IPP) in Greifswald produced its first hydrogen plasma on 3 February 2016. This marks the start of scientific operation. Wendelstein 7-X, the world’s largest fusion device of the stellarator type, is to investigate this configuration’s suitability for use in a power plant.

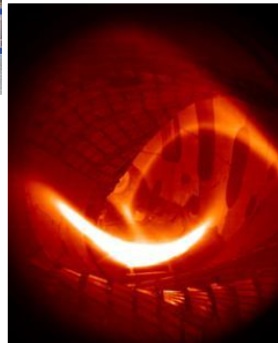

Since the start of operation on 10 December 2015 Wendelstein 7-X has produced more than 300 discharges with the rare gas, helium. These served primarily to clean the plasma vessel. The cleaner the vessel wall, the more the plasma temperature increased, finally attaining six million degrees Celsius. The first plasma heating and testing, and the first for investigating the operation, viz. components such as X-ray spectrometers, interferometers, video diagnostic systems, are ready for the next steps. Head Professor Dr. Rüdiger Brändl and his team are changing the parameters of the plasmas, our investigation

### Magnetic field of Wendelstein 7-X exact to a hundred-thousandth

Evaluation of magnetic field measurement / Overview in “Nature Communications”

November 30, 2016

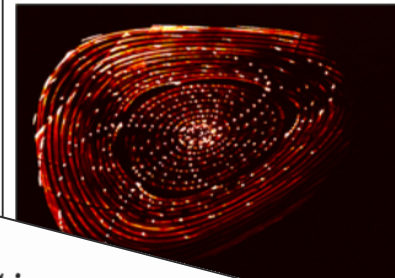

The shape of the magnetic field needed in the Wendelstein 7-X stellarator fusion device was achieved to a precision of a hundred-thousandth. This evaluation of the first physical results with the new machine – these having been achieved before Wendelstein 7-X went into operation at Max Planck Institute for Plasma Physics in Greifswald in December 2015 – appeared today in the online journal, “Nature Communications”.

**Magnet tests on Wendelstein 7-X successfully completed**  
 Important step in the preparation for operation / first plasma in the fusion  
 July 07, 2015

**Confirmation of the topology of the Wendelstein 7-X magnetic field to better than 1:100,000**  
 T. Sunn Pedersen, M. Otte, S. Lazerson, P. Helander, S. Bozhenkov, C. Biedermann, T. Klinger, R. C. Wolf, H.-S. Bosch & The Wendelstein 7-X Team

# Success story light sources

# SCU's: the next generation Insertion device

Typical parameters	Value	Units
Period length	15	mm
Full periods	100.5	
Max field on axis 7 mm gap	0.73	T
Nominal current	150	A
Ramp to nominal current	450	s
Operating gap	7	mm
Injection gap	15	mm
Beam heat load	4	W
Design temperature	4.2	K

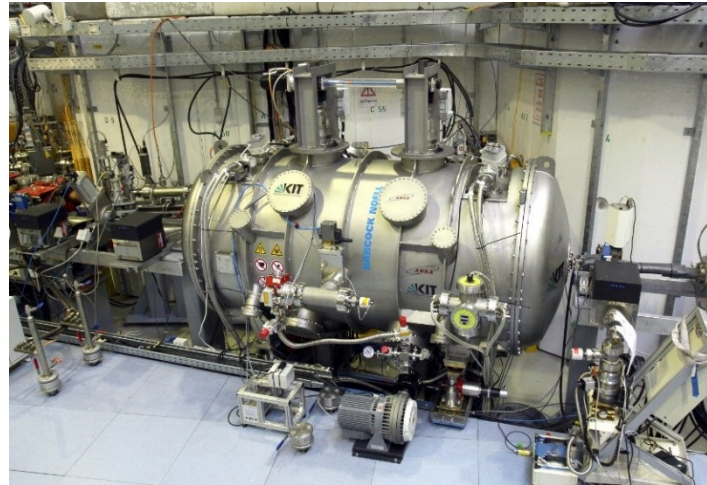

SCU 15 in the ANKA ring

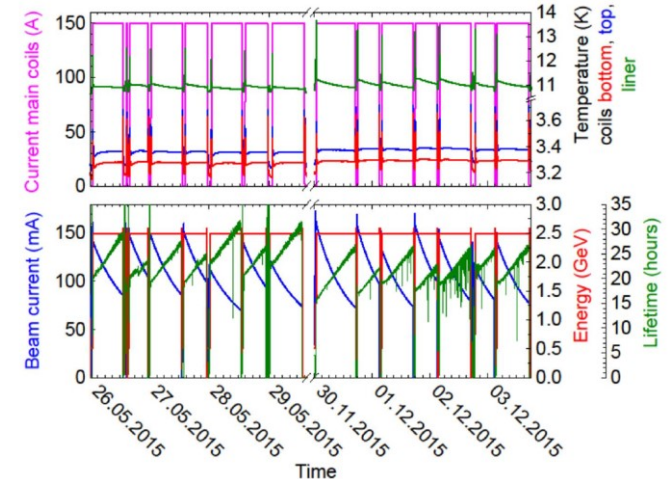

## KIT and Babcock Noell GmbH is pushing the state of the art of insertion devices:

- Cooperation agreement between KIT and Babcock Noell
- KIT responsible for beam dynamics and cold test of coils before assembly
- Babcock Noell responsible for magnet design, manufacturing and in house cold test
- Final test in the ring done by KIT

Babcock Noell GmbH



# Success story for superconducting undulators



## Novel superconducting undulator provides first X-ray light at ANKA

30 April 2015

### New insertion device for Light Source and FEL community

- SCU 15 demonstrated to reach higher flux and brilliance than any other technology.
- These devices are highly reliable, are completely transparent in a storage ring
- SCU's deliver unprecedented performance.



# Success story accelerators

# SIS 100: Development of a Fast Ramping SC Dipoles

## EU-FP6 Task: GSI with partners from institutes and industries:

- Strong dynamical forces / High accuracy and reproducibility

## Babcock Noell contributions to EU-FP6 program:

- Manufacturing design and layout
- Winding scheme and tooling concept
- Preparation of test samples and measurement of properties

## First straight prototype

- Fabrication of prototype via supply contract
- Basic design and cold tests performed by GSI



1st straight prototype

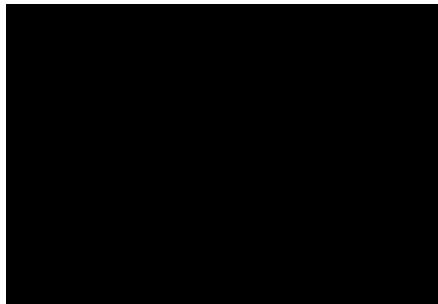

Coil with structural elements



Samples for testing



Cable manufacturing

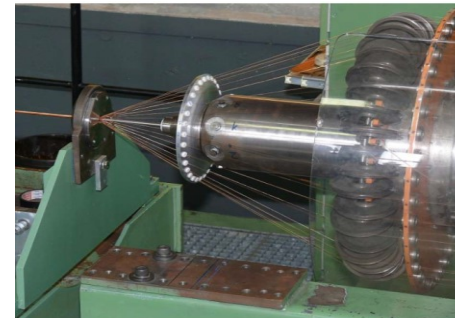

Winding

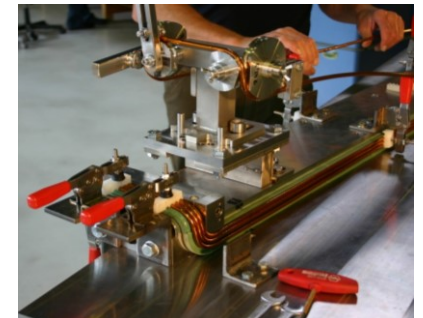



# SIS 100: Series production for FAIR @ GSI

## Fast ramped superferric dipoles:

- Fast ramping → 4 T/s
- NbTi, Nuclotron Cable
- Length ~3 m. Magnetic Field 1.9 T

## First of series - FOS

- Industrial manufacturing of the SC cable
- Qualification for the industrial series production
- FOS successfully tested
- Series production released

## Series

- Cable production finished
- Manufacturing of 110 series magnets started
- Cold tests of the magnets @ GSI

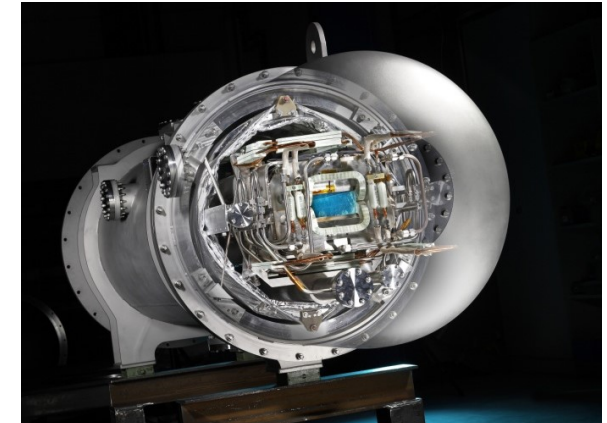
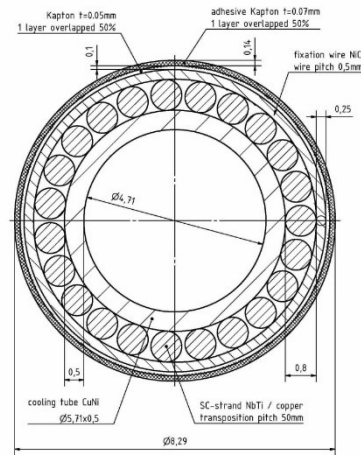

# LHC Dipoles: Development phase

## CERN's contribution

- Design of the magnets
- 1 meter prototypes and technical support
- Cold test of the magnets
- And much more...

## BNG's Contribution for Prototyping

- 1990: 10 m Prototype Cold Masses
- 1995: 10 m All Kapton Collared Coil
- 1997: Tooling Extension 15 m
- 1999: Two 15 m Prototype Collared Coils
- 1999: Preparation for Series Production

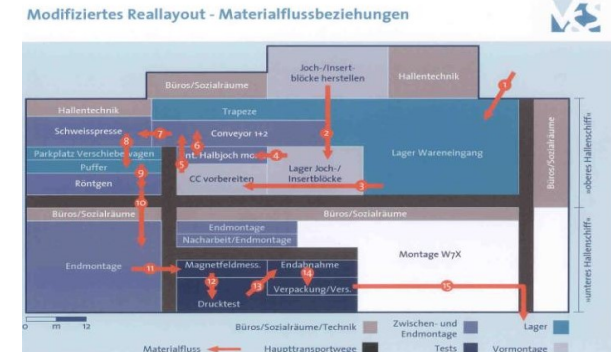
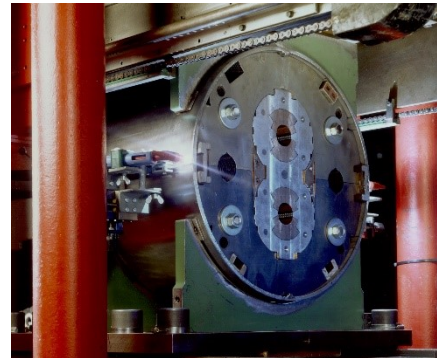

# LHC Dipoles: Series production

## Technical Data:

- Length 15 m; weight 30 t
- Magnetic field 8.33 T
- Operating current 11.8 kA @1.9 K

## CERN's contribution:

- Large scale material supply
- Expediting of supply chain
- Cold test of the magnets and ...

## BNG's part:

- 1999: 30 Cold Masses
- 2002 - 2006: 386 Cold Masses

**Up to 4 magnets per week,  
delivery 7 months ahead of schedule**

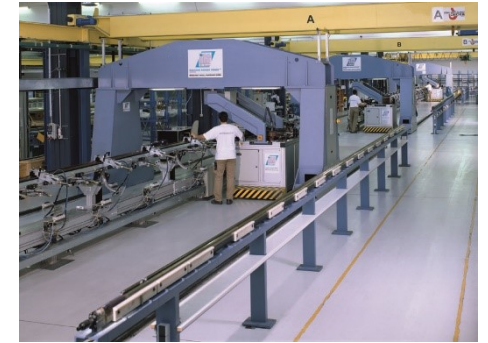
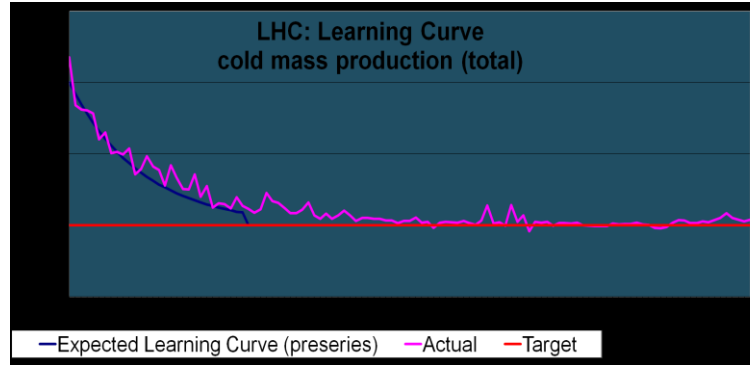

# LHC Dipoles: Network of direct CERN suppliers

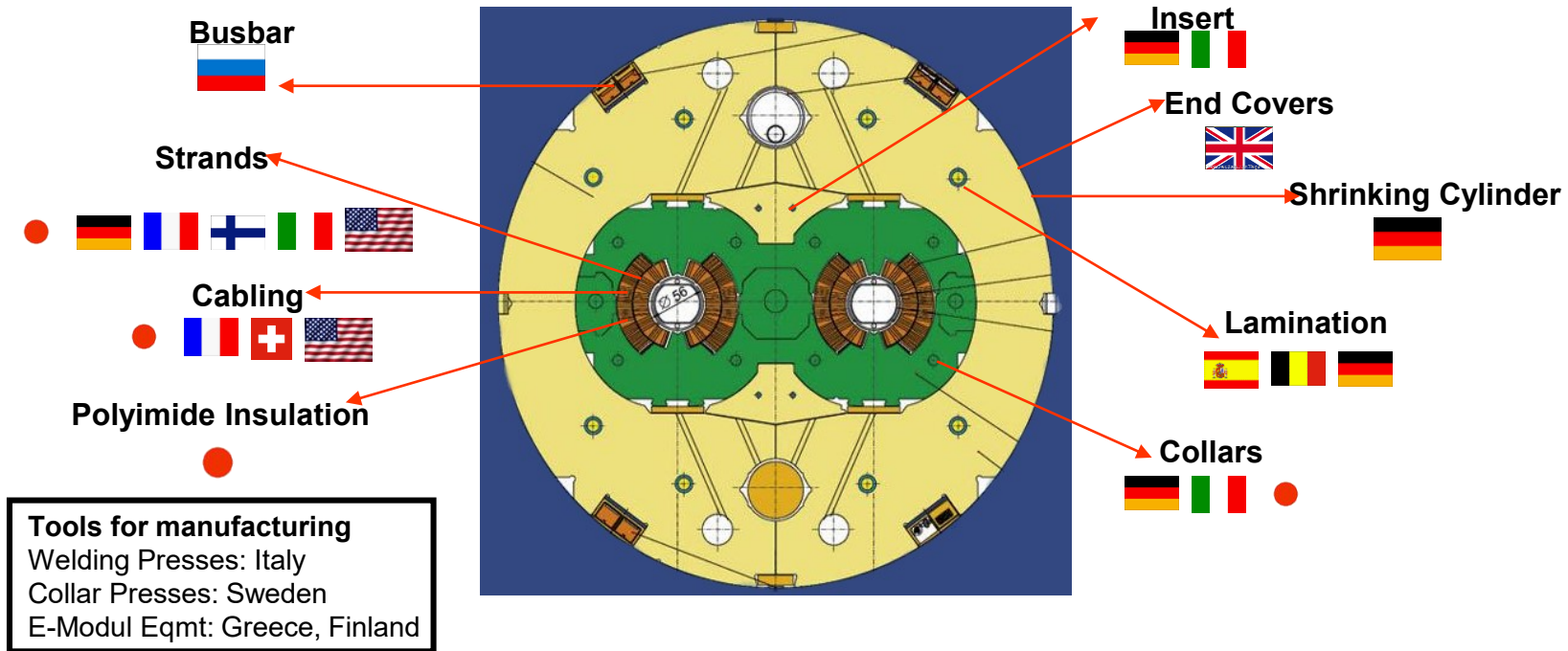

- Most of material supplied from CERN to magnet manufacturer
- Customer driven provision of material with numerous single contracts
- Timely delivery and logistics for tools and material is customer responsibility

# LHC Upgrade: the next step

- CERN asked companies for development and industrialization work in LMF
- Collaboration for Nb<sub>3</sub>Sn costheta magnets for 11T dipoles and quadrupoles
- Babcock Noell's scope cover all production steps
- At CERN LMF available and all experts and expertise
- Industry contributes with manufacturing know how and workforce

Winding and Curing

MQXF

Reaction heat treat.

11 T dipole

Splicing

11 T dipole

VP-Impregnation

11 T dipole

Magnet assembly

MQXF



Pictures: Copyright CERN

# FCC: The Future

LHC and LHC Upgrade are the ideal basis for the next giant step

There is **experience available** in institutes and EU industry from large scale research projects that can be transferred to FCC.

Collaboration between institutes and industries can be **beneficial for customer and supplier if a suitable collaboration scheme** (win-win situation) is implemented.

A fair competition and **equally capable suppliers** are an **important** precondition.

**Early implementation** of cooperation schemes are essential

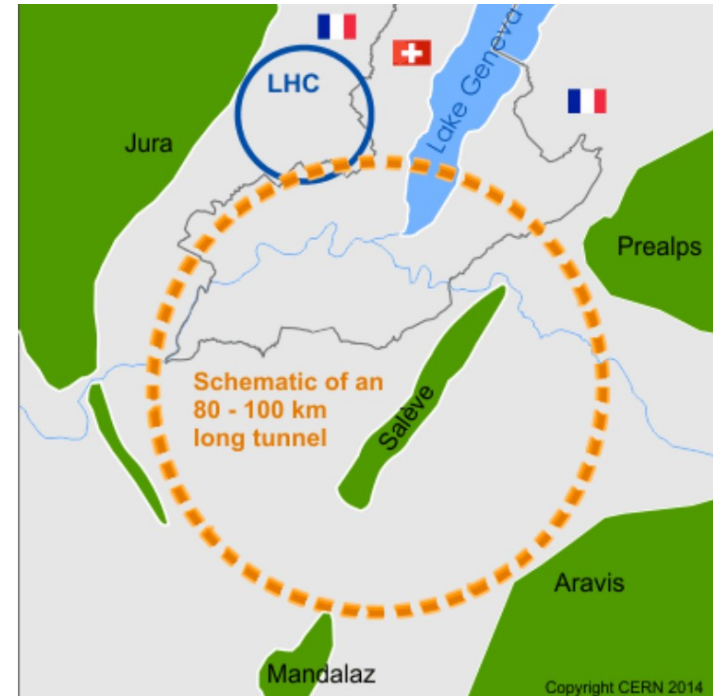

# Success story for accelerator magnets



Babcock Noell received the Golden Hadron Award

## The LHC collides ions at new record energy

25 Nov 2015

Geneva, 25 November 2015. After the successful restart of the Large Hadron Collider and its first months of data taking with proton collisions at a new energy frontier, the LHC is moving forward with the first lead-ion collisions of season 2 at an energy about twice as high as that of the collider experiment. Following a period of intense activity to re-configure the LHC and



ATLAS and CMS experiments shed light on Higgs properties

Higgs boson announcement: Cern scientists discover subatomic particle  
Scientists gather for a major announcement in Cern, home of the Large Hadron Collider

Superheavy element 117 weighs in again  
May 9, 2014 1 comment

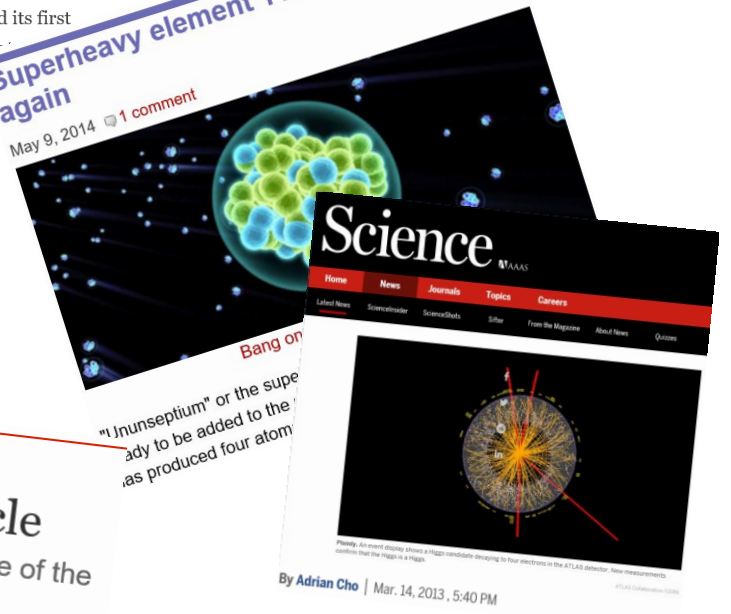

# Factors of the success



# Factors of success: a personal opinion

## Assets of academia

- Academia has the **research expertise** for development, conceptual and basic design
- For long term projects (LHC, FCC, ILC) **predevelopment work** is an essential asset
- **Lots of experts** present for examination of magnets, conductors, materials, etc.
- **Infrastructure available** for comprehensive tests as cold tests, material characterisation, etc.

## Assets of industry

- Know how about **engineering design and manufacturing** of SC magnets
- Expertise how to build **effectively and cost-efficient** magnets and series
- There is **experience** available from large scale projects that can be **transferred** to ILC, FCC, DEMO.
- Industry has available **production facilities** and can **establish infrastructures** for series productions

## Factors of success: a personal opinion

### Co-operations are essential for the success.

- Industry can contribute to research projects during development by
  - ✓ Common funding's (i.e. Horizon 2020 – FuSuMaTech ...)
  - ✓ Studies (Feasibility, Industrialization, Cost + Schedule)
  - ✓ Prototyping
- Academia should support industry by
  - ✓ Providing infrastructure and expertise for sophisticated tests
  - ✓ Support product development on a case by case basis
  - ✓ and of course “create new physics and work out experiments to validate it”

**There is an exciting future for superconducting magnets ahead.**

# Magnet-Technology – YOUR Team



**WE  
MAKE  
COOPERATION  
WORK!**

*Thank you!*